

item	type	KS2U-238/* G	KS2U-212/* G
port size		G 3/8	G 1/2
description		sinter filter centrifugal principle diaphragm-type pressure regulator with secondary air exhaust lubricator with automatic oil filling	
medium		compressed air, neutral gases	
mounting		vertical	
medium- and ambient temperature		max. 50 °C	
supply pressure		Pe max. 16 bar Pe min. 1,5 bar semi-automatic and fully automatic drain	
filter element		5 µm standard	
bowl volume		filter-regulator: 49 cm ³ , lubricator: 80 cm ³	
drain model		semi-automatic	
reduced pressure [3]		0,5 - 8 bar, 0,1-1 bar, 0,1-2 bar, 0,2-4 bar, 0,5-10 bar, 0,5-16 bar	
oil metering qv=1000l/min		1 - 2 drops / min	
oil type		CL 32 nach DIN 51517 - ISO VG 32	
fixing		control panel installation, mounting bracket, wall mounting	
weight		1,010 kg	



parts (Service-Kit: ESA.2-1311)

no.	designation		material	order-no.
1	spring cage	FH.2-600	POM	---
2	setting knob	FH.2-625	POM	---
3	spring	FED.2-703	galvanised steel	---
4	membrane	C.22-75	brass-NBR-PA6	
5	valve cone	VK.2-420	brass-NBR	
6	o-ring 37,5 x 2,5	OR.0-5	NBR	
7	spring	FED.2-720	stainless steel	---
8	condensate bowl	BE.2 HA4	plycarbonate	90002.0200
9	filter element 5µm	C.22-26	cellpor	5.2122.26.000
10	bowl	BE.2 LUB	plycarbonate	90002.0202
11	dome assembly	ESA-1-1312	plycarbonate	99901.1312
12	o-ring 37,5 x 2,5	OR.0-1	NBR	

application information

- Filter transmittance according to ISO 4003, glass bead test
- Setting knob can be locked by pressing downwards
- Regulator head lockable
- Can be filled with oil during operation



series 2

ordering information

KS2U - * / * ***

type

[1] port size

[2] accessories

[3] reduced pressure

ordering example: KS2U-212/8 AM G

[1]	port size	
	238	G 3/8
	212	G 1/2
	238 NPT	3/8-18 NPT
	212 NPT	1/2-14 NPT
[2]	accessories (see reverse side)	
	S	control panel nut
	H	metal bowl with level indicator
	AM	fully automatic drain pressureless open
	AM NC	fully automatic drain pressureless closed
[3]	reduced pressure (see item table)	
	e.g. 8	0,5 - 8 bar

dimensions (mm)

tightening torque for control panel nut: 9 Nm

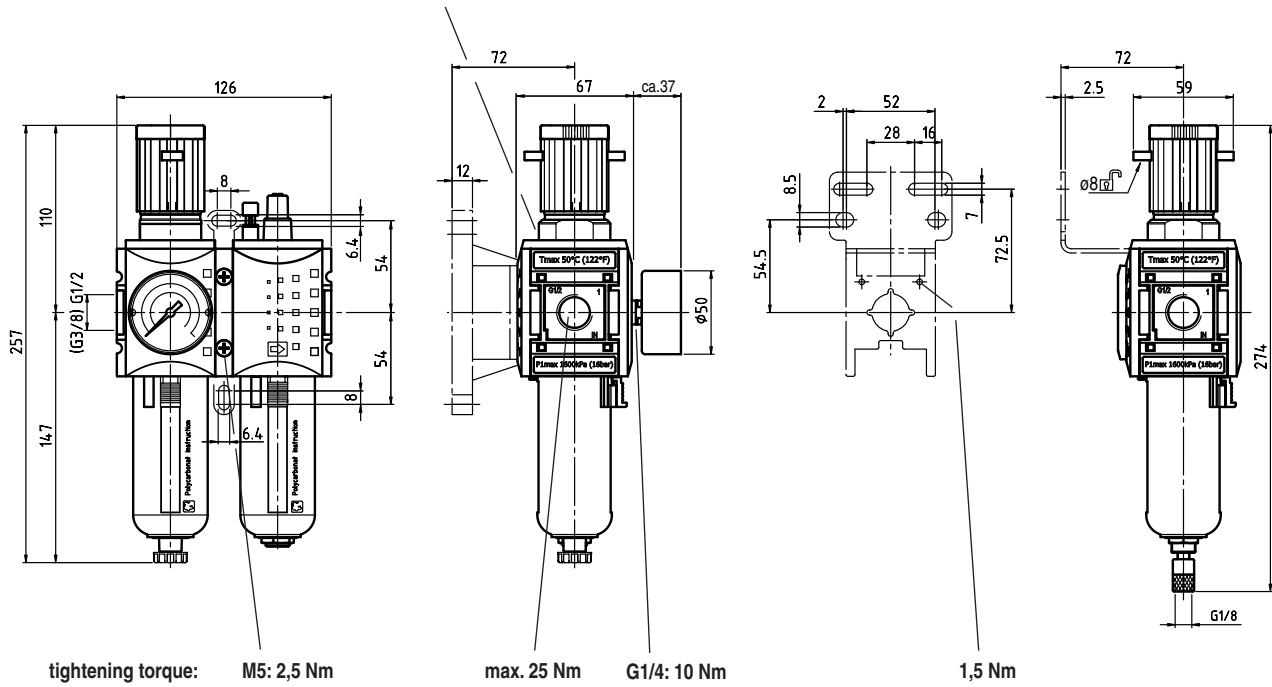

flow characteristic

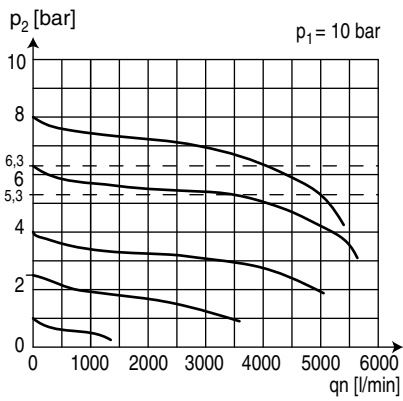

lubricator operating limit

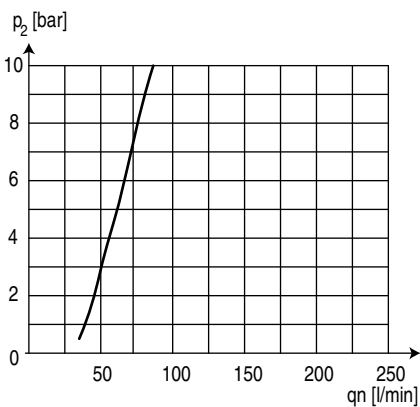

accessories

2

